



FAMILIES ARE PART OF THE SOLUTION

# Strengthening Michigan's Families

An Innovative Approach to Improving Safety and Family Well-being

## Strength-Based Genogram

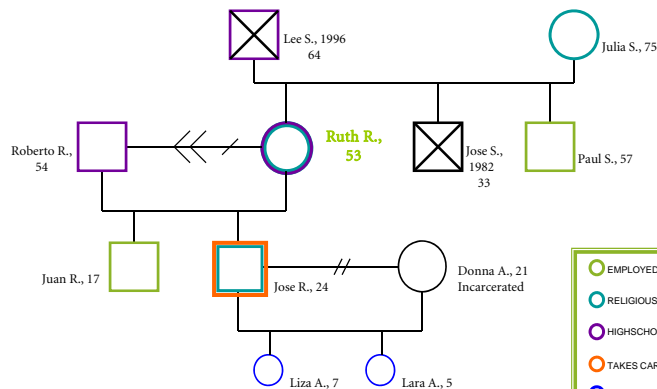

FAMILIES ARE PART OF THE SOLUTION

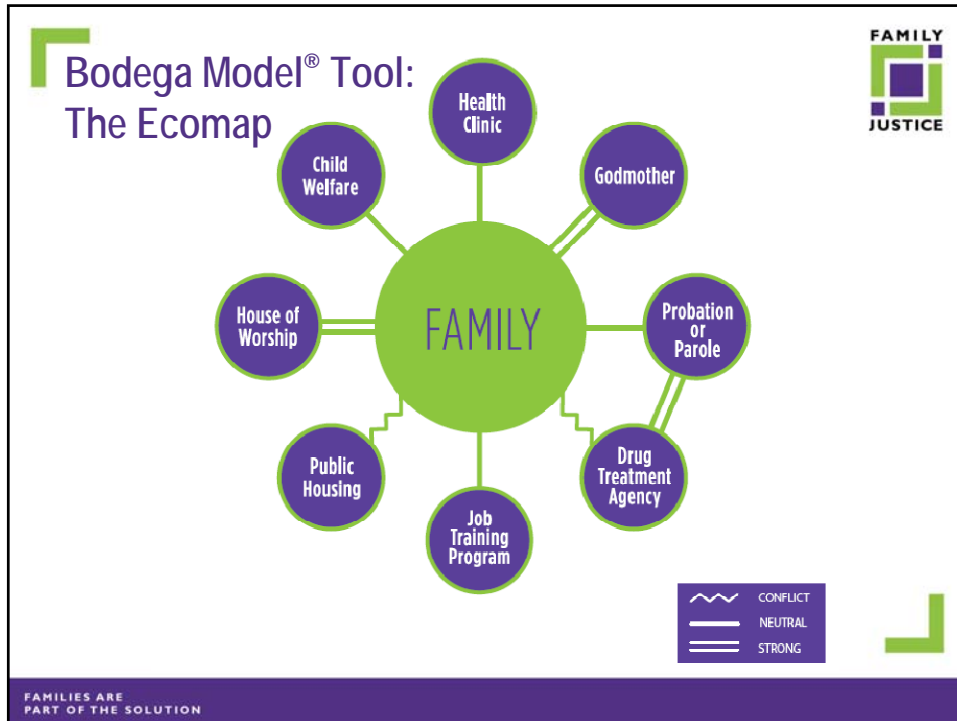

**What the Research Says**

**FAMILY JUSTICE**

Incarcerated men who maintain “strong family ties” while in jail or prison demonstrate higher levels of post-release success than those who do not. (Hairston, 2002)

“Intimate partner and family relationships [are] significantly related to the intermediate reentry outcomes of employment and staying off drugs.” (Visher et al., 2004)

Juveniles who work with probation officers using a strengths-based approach are 81% less likely to be re-arrested (Kurtz and Linnemann, 2006)

Through strength-based, family-focused case management at La Bodega de la Familia, rates of substance abuse dropped among participants from 80% to 42% (Vera Institute of Justice, 2001)

FAMILIES ARE PART OF THE SOLUTION



## Family-Focused Work around the Country

- Assessment
  - Family Justice’s Relational Inquiry Tool
- Validation of Staff Expertise
  - Tapping staff experience and know-how to build on current practices and leverage social capital of families
  - Oklahoma, Iowa, American Probation & Parole Assoc.
- Innovative Programming in Jails and Prisons
  - California increasing calls for youth to families
  - New York reducing collect-call rates
  - Oklahoma letter-writing project
- Visitation policies and Family Support in the Community
  - Michigan’s Family Reunification Sessions
  - Ohio’s Children of Incarcerated Parents Program
  - Differentiating the challenges in rural, suburban, and urban settings

FAMILIES ARE PART OF THE SOLUTION



## What Michigan Is Doing...and Can Do!

- As prisons close, Michigan may see parole caseloads increase and social services strained
  - Introduce tools to corrections professionals that help **maintain familial connections** while individuals are incarcerated
  - Involve families as a **partner in community supervision**
  - **Foster interagency collaboration** to reduce siloed funding and conflicting mandates

FAMILIES ARE PART OF THE SOLUTION

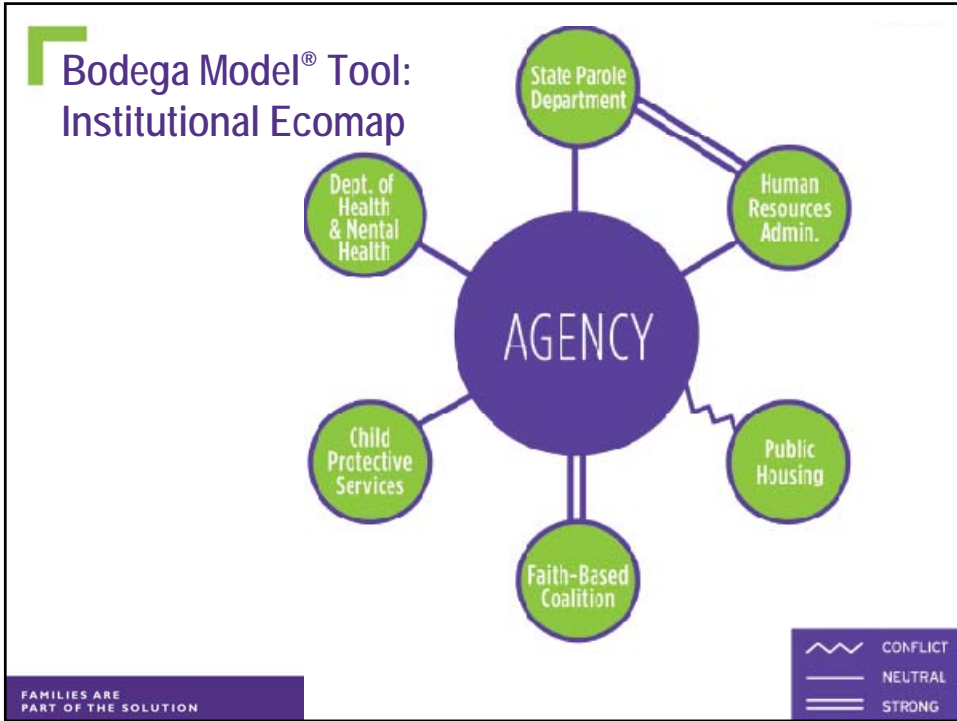

Traditional Practice	Family-Focused Approach
Focuses on the individual leaving jail/prison, or under parole/probation/child welfare supervision	Focuses on the <b>support and family connections</b> of the individual leaving jail/prison or under parole/probation/child welfare supervision
Driven by individuals' and families' risks and needs	Driven by <b>strengths, assets, and connections</b> of individuals and families
Measures individual clients' outcomes	Measures outcome of the <b>entire family</b>
Responds to truancy and gang-related issues primarily with law enforcement	Responds to truancy and gang-related issues with <b>partnerships</b> between families and law enforcement

FAMILY JUSTICE

FAMILIES ARE PART OF THE SOLUTION



FAMILIES ARE  
PART OF THE SOLUTION

Carol Shapiro  
Founder and President

[cshapiro@familyjustice.org](mailto:cshapiro@familyjustice.org)

(212) 475-1500

[www.familyjustice.org](http://www.familyjustice.org)